

簡易ADロガー(FAT32対応)(PIC18F2523)

概要

今迄に、SDカード(FAT16)を利用したロガーやタイマーを各種製作してきましたが、最大容量が2GBの制約がありました。しかし、使用用途によってはファイル容量をもっと増やしたいという要望がありました。



SDカード<FAT16>(例)

この程、マイクロエレクトロニカ(mikroElektronika)社よりFAT32のライブラリが提供されたので、早速適用してみました。FAT32は最大で2TBと十分に大きいので上記のような問題は発生しないのではと思っています。



SDカード<FAT32>(例)

◎FAT32ライブラリ

- 1333712413_fat32_library_mikroc_pic.mpkg

Dependency Routines

- FAT32_Dev_Init
- FAT32_Dev_Read_Sector
- FAT32_Dev_Write_Sector
- FAT32_Dev_SectorCount
- FAT32_Dev_Multi_Read_Start
- FAT32_Dev_Multi_Read_Stop
- FAT32_Dev_Multi_Read_Sector
- FAT32_Put_Char

Library Routines

- FAT32_Init
- FAT32_Format
- FAT32_ScanDisk
- FAT32_GetFreeSpace
- FAT32_Dir
- FAT32_MakeDir
- FAT32_ChangeDir
- FAT32_FindFirst
- FAT32_FindNext
- FAT32_Exists
- FAT32_Rename
- FAT32_Delete
- FAT32_DeleteRec
- FAT32_Open
- FAT32_Close
- FAT32_Read
- FAT32_Write
- FAT32_Tell
- FAT32_Seek
- FAT32_Eof
- FAT32_Size
- FAT32_SetAttr
- FAT32_GetAttr
- FAT32_GetFileHandle
- FAT32_SetTime
- FAT32_IncTime
- FAT32_GetCTime
- FAT32_GetMTime
- FAT32_GetError
- FAT32_MakeSwap

パッケージマネージャ(ライブラリを[mikroC PRO]に登録するためのツール)

- package-manager

仕様

記録媒体

- SDカード(FAT32)

入力チャンネル

- 8チャンネル

測定周期(サンプリング速度)

- 100msec□1sec□1min□10min

平均測定回数

- 1回、10回、100回

測定分解能

- A/D変換12ビット(4096)、基準電圧=3.3V
- 約0.8mV(3.3V÷4096)

入力電圧範囲

- 0V~3.3V(分圧抵抗を付加することにより範囲を拡張することが可能)

動作原理(ハードウェア)

◎SDカードの電圧は、3.3Vなので全体を3.3V駆動とします。電源は、1.2Vの充電電池を4本使用し、4.8Vとします□◎4.8Vを3.3Vの三端子レギュレータで3.3Vに降圧します。アナログデータは直接PICに入力するので入力電圧範囲は、0V~3.3Vとします。分圧抵抗を付加することにより入力電圧範囲を拡張することができます。

動作原理(ソフトウェア)

事前に、[mikroC PRO]に、FAT32ライブラリを登録します□◎PICのクロックを32MHzに設定します□`init_osc()`◎コンパレータを設定します□`init_comparator()`◎ポートを設定します□`init_port()`◎ADCを設定します□`init_adc()`◎SDCを初期化します□`init_sdc_fat32()`◎タイマ(10msecの周期割り込み用)を設定します□`init_timer()`◎LEDを3回点滅させます。スタートスイッチ(SW_START)が押下されるのを待ちます。ファイルをオープンします。測定および結果のSDカードへの書き込みを行います□`measurement()`◎ファイルをクローズします。

回路図

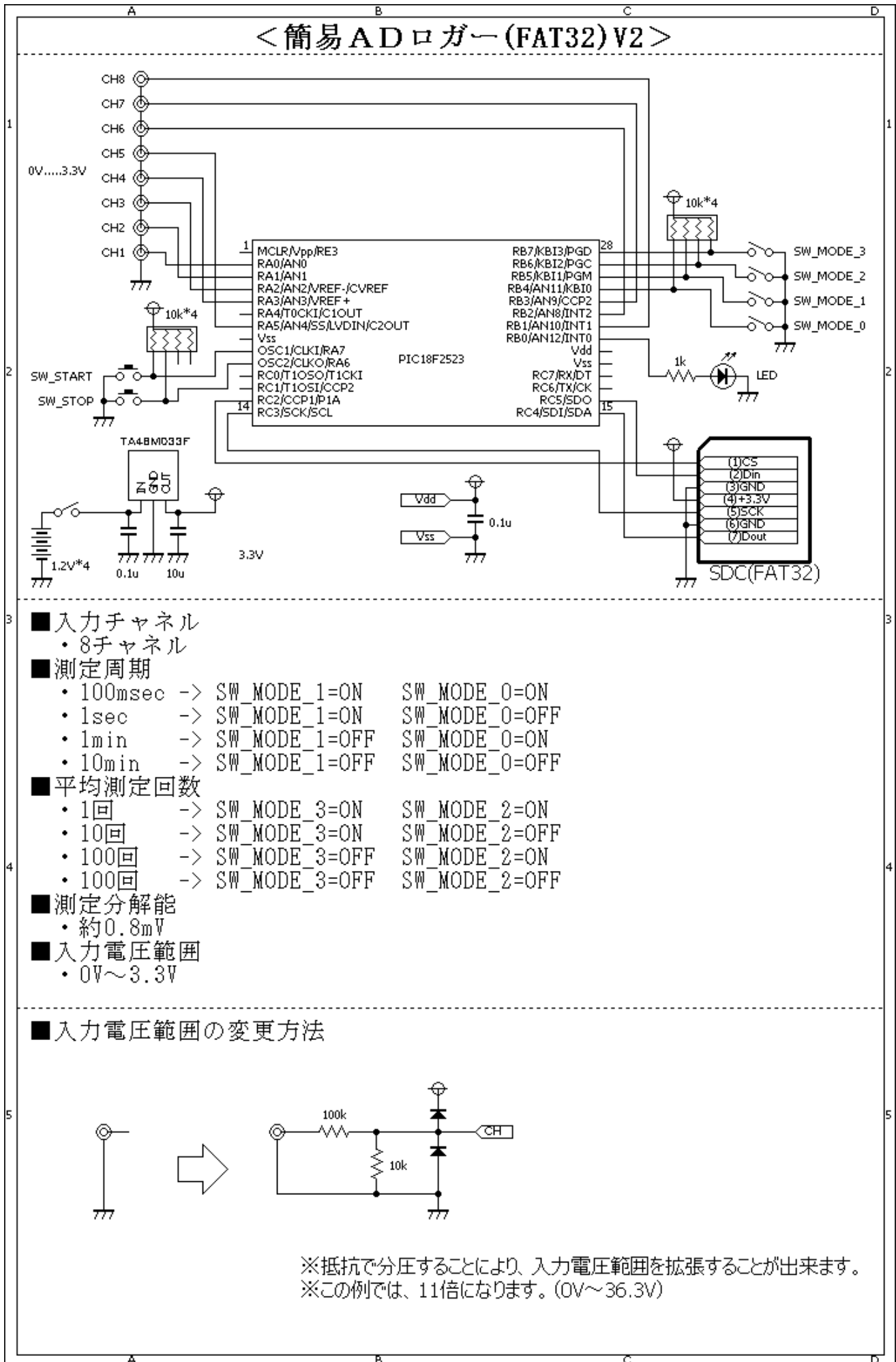

ソースコード

simple_ad_logger_fat32_v2.c

```
//*****
*****
/*
   <簡易ログ(FAT32)
   ・アナログ入力8チャンネル
   ログ(FAT32)
*/
//*****
*****

#define BYTE    unsigned    short
#define WORD    unsigned    int
#define DWORD   unsigned    long
//
#define FAT32
//
#ifdef FAT32
#include "__Lib_FAT32.h"
#endif
//
sbit    SW_START    at    RA7_bit;
sbit    SW_STOP     at    RA6_bit;
//
sbit    SW_MODE_0   at    RB4_bit;
sbit    SW_MODE_1   at    RB5_bit;
sbit    SW_MODE_2   at    RB6_bit;
sbit    SW_MODE_3   at    RB7_bit;
//
sbit    LED         at    RB0_bit;
//*****
*****

extern void    main();
extern void    measurement();
//
extern void    init_osc();
extern void    init_port();
extern void    init_comparator();
extern void    init_adc();
extern void    init_sdc_fat32();
extern void    init_sdc();
extern void    init_timer();
//
extern DWORD  get_clock();
extern void   set_clock(DWORD clock);
extern void   clock2str(DWORD clock, char *str);
extern void   clock2timedate(DWORD clock, __TIME *tm);
```

```
extern long wait_trigger(short mode);
extern WORD ADC_Get_Sample_Average(BYTE channel, short
sampling_count);
extern short get_cycle_mode();
extern short get_average_cnt();
//*****
*****
char buf[64];
char *file_name = "log_0000.txt";
WORD file_id = 0;
#ifdef FAT32
__HANDLE fileHandle;
__TIME TimeDate;
#endif
//*****
*****
// メイン関数
void main()
{
    DWORD clock;
    short cnt;
    //
    init_osc();
    init_comparator();
    init_port();
    init_adc();
#ifdef FAT32
    init_sdc_fat32();
#else
    init_sdc();
#endif
    init_timer();
    //
    for (cnt = 0; cnt < 3; cnt++) {
        LED = 1;
        Delay_ms(500);
        LED = 0;
        Delay_ms(500);
    }
    //
    while (1) {
        if (SW_START != 0) {
            continue;
        }
        //
        LED = 1;
        //
        file_id++;
        WordToStr(file_id, buf);
        file_name[4] = (buf[1] == ' ') ? '0' : buf[1];
        file_name[5] = (buf[2] == ' ') ? '0' : buf[2];
    }
}
```

```
        file_name[6] = (buf[3] == ' ') ? '0' : buf[3];
        file_name[7] = (buf[4] == ' ') ? '0' : buf[4];
#ifdef FAT32
        clock2timedate(get_clock(), &TimeDate);
        FAT32_SetTime(&TimeDate);
        FAT32_Delete(file_name);
        fileHandle = FAT32_Open(file_name, FILE_WRITE);
        FAT32_Write(fileHandle, "$START\r\n", 8);
#else
        Mmc_Fat_Assign(file_name, 0);
        Mmc_Fat_Delete();
        Mmc_Fat_Set_File_Date(2012, 12, 27, 12, 34, 56);
        Mmc_Fat_Assign(file_name, 0xA0);
        Mmc_Fat_Rewrite();
        Mmc_Fat_Write("$START\r\n", 8);
#endif
        measurement();
#ifdef FAT32
        FAT32_Write(fileHandle, "$STOP\r\n", 7);
        FAT32_Close(fileHandle);
#else
        Mmc_Fat_Write("$STOP\r\n", 7);
#endif
        LED = 0;
    }
}
//*****
void measurement()
{
    double ch1, ch2, ch3, ch4, ch5, ch6, ch7, ch8;
    long clock;
    short cnt;
    //
    cnt = get_average_cnt();
    //
    while (SW_STOP != 0) {
        clock = wait_trigger(get_cycle_mode());
        if (clock == -1) {
            break;
        }
        //
        clock2str(clock, buf);
        //
        ch1 = ADC_Get_Sample_Average(0, cnt);
        ch2 = ADC_Get_Sample_Average(1, cnt);
        ch3 = ADC_Get_Sample_Average(2, cnt);
        ch4 = ADC_Get_Sample_Average(3, cnt);
        ch5 = ADC_Get_Sample_Average(4, cnt);
        ch6 = ADC_Get_Sample_Average(8, cnt);
```

```
    ch7 = ADC_Get_Sample_Average(9, cnt);
    ch8 = ADC_Get_Sample_Average(10, cnt);
    //
    ch1 *= 0.8056640625;
    ch2 *= 0.8056640625;
    ch3 *= 0.8056640625;
    ch4 *= 0.8056640625;
    ch5 *= 0.8056640625;
    ch6 *= 0.8056640625;
    ch7 *= 0.8056640625;
    ch8 *= 0.8056640625;
    //
    WordToStr(ch1, &buf[12]);
    WordToStr(ch2, &buf[17]);
    WordToStr(ch3, &buf[22]);
    WordToStr(ch4, &buf[27]);
    WordToStr(ch5, &buf[32]);
    WordToStr(ch6, &buf[37]);
    WordToStr(ch7, &buf[42]);
    WordToStr(ch8, &buf[47]);
    buf[52] = '\r';
    buf[53] = '\n';
    //
#ifdef FAT32
    FAT32_Write(fileHandle, buf, 54);
#else
    Mmc_Fat_Write(buf, 54);
#endif
}
}
//*****
*****
short get_cycle_mode()
{
    if ((SW_MODE_1 == 0) && (SW_MODE_0 == 0)) {
        return (0);
    }
    if ((SW_MODE_1 == 0) && (SW_MODE_0 == 1)) {
        return (1);
    }
    if ((SW_MODE_1 == 1) && (SW_MODE_0 == 0)) {
        return (2);
    }
    if ((SW_MODE_1 == 1) && (SW_MODE_0 == 1)) {
        return (3);
    }
}
//*****
*****
short get_average_cnt()
{
```

```
    if ((SW_MODE_3 == 0) && (SW_MODE_2 == 0)) {
        return (1);
    }
    if ((SW_MODE_3 == 0) && (SW_MODE_2 == 1)) {
        return (10);
    }
    if ((SW_MODE_3 == 1) && (SW_MODE_2 == 0)) {
        return (100);
    }
    if ((SW_MODE_3 == 1) && (SW_MODE_2 == 1)) {
        return (100);
    }
}
//*****
*****
long wait_trigger(short mode)
{
    long clock;
    //
    switch (mode) {
    case 0: //100msec
        while (1) {
            clock = get_clock();
            if ((clock % 10) == 0) {
                return(clock);
            }
            if (SW_STOP == 0) {
                return(-1);
            }
        }
        break;
    case 1: //1sec
        while (1) {
            clock = get_clock();
            if ((clock % 100) == 0) {
                return(clock);
            }
            if (SW_STOP == 0) {
                return(-1);
            }
        }
        break;
    case 2: //1min
        while (1) {
            clock = get_clock();
            if ((clock % 6000) == 0) {
                return(clock);
            }
            if (SW_STOP == 0) {
                return(-1);
            }
        }
        break;
    }
}
```

```

        }
    }
    break;
case 3: //10min
    while (1) {
        clock = get_clock();
        if ((clock % 60000) == 0) {
            return(clock);
        }
        if (SW_STOP == 0) {
            return(-1);
        }
    }
    break;
}
return (-1);
}
}
//*****
*****
WORD    ADC_Get_Sample_Average(BYTE channel, short sampling_count)
{
    int    cnt;
    DWORD  ad;
    //
    ad = 0;
    for (cnt = 0; cnt < sampling_count; cnt++) {
        ad += ADC_Get_Sample(channel);
    }
    return (ad / sampling_count);
}
//*****
*****
void    clock2str(DWORD clock, char *str) //"00:00:00:000"
{
    BYTE    hh, mm, ss, ms;
    char    tmp[4];
    //
    hh = (clock % 8640000) / 360000;
    mm = (clock % 360000) / 6000;
    ss = (clock % 6000) / 100;
    ms = clock % 100;
    //
    ByteToStr(hh, tmp);
    str[0] = (tmp[1] == ' ') ? '0' : tmp[1];
    str[1] = tmp[2];
    str[2] = ':';
    ByteToStr(mm, tmp);
    str[3] = (tmp[1] == ' ') ? '0' : tmp[1];
    str[4] = tmp[2];
    str[5] = ':';
    ByteToStr(ss, tmp);

```

```
    str[6] = (tmp[1] == ' ') ? '0' : tmp[1];
    str[7] = tmp[2];
    str[8] = ':';
    ByteToStr(ms, tmp);
    str[9] = (tmp[1] == ' ') ? '0' : tmp[1];
    str[10] = tmp[2];
    str[11] = '0';
    str[12] = 0x00;
}
//*****
*****
void    clock2timedate(DWORD clock, __TIME *tm)
{
    tm->Year    = 2012;
    tm->Month   = 12;
    tm->Day     = 27;
    tm->Hour    = (clock % 8640000) / 360000;
    tm->Minute  = (clock % 360000) / 6000;
    tm->Second  = (clock % 6000) / 100;
}
//*****
*****
DWORD   clock = 0;
DWORD   clock_tmp = 0;
short   clock_flg = 0;
//
void    interrupt()
{
    if (PIR1.CCP1IF == 1) {
        PIR1.CCP1IF = 0;
        //
        clock++;
        switch (clock_flg) {
            case 1:
                clock_flg = 0;
                clock_tmp = clock;
                break;
            case 2:
                clock_flg = 0;
                clock = clock_tmp;
                break;
        }
    }
}
//*****
*****
DWORD   get_clock()
{
    clock_flg = 1;
    while (clock_flg == 1) {
```

```

    }
    return (clock_tmp);
}
//*****
void set_clock(DWORD clock)
{
    clock_tmp = clock;
    clock_flg = 2;
    while (clock_flg == 2) {
    }
}
//*****
// 周期割り込み設定関数(10msec)
void init_timer()
{
    // CCPの設定
    PIE1.CCP1IE = 1;
    PIR1.CCP1IF = 0;
    CCP1CON.CCP1M3 = 1;
    CCP1CON.CCP1M2 = 0;
    CCP1CON.CCP1M1 = 1;
    CCP1CON.CCP1M0 = 1;
    CCPR1L = 0x10; // 10msec...クロックが32Mhzの時
    CCPR1H = 0x27; //
    10msec...(1÷32000000)*4*8*10000(0x2710)
    // TIMER1の設定
    PIE1.TMR1IE = 0;
    PIR1.TMR1IF = 0;
    TMR1L = 0;
    TMR1H = 0;
    T1CON.TMR1CS = 0;
    T1CON.T1CKPS0 = 1;
    T1CON.T1CKPS1 = 1;
    T1CON.TMR1ON = 1;
    //
    INTCON.PEIE = 1;
    INTCON.GIE = 1;
}
//*****
//■□□を初期化する関数です。
#ifdef FAT32
sfr sbit Mmc_Chip_Select at RC2_bit;
sfr sbit Mmc_Chip_Select_Direction at TRISC2_bit;
//
void init_sdc_fat32()
{
    SPI1_Init_Advanced(_SPI_MASTER_OSC_DIV64,
        _SPI_DATA_SAMPLE_MIDDLE, _SPI_CLK_IDLE_LOW, _SPI_LOW_2_HIGH);
}

```

```
while (FAT32_Init() < 0) {
    LED = 1;
    Delay_ms(50);
    LED = 0;
    Delay_ms(50);
}
SPI1_Init_Advanced(_SPI_MASTER_OSC_DIV4,
_SPI_DATA_SAMPLE_MIDDLE, _SPI_CLK_IDLE_LOW, _SPI_LOW_2_HIGH);
}
#endif
//*****
//■■■■を初期化する関数です。
#ifdef FAT16
sfr sbit Mmc_Chip_Select          at RC2_bit;
sfr sbit Mmc_Chip_Select_Direction at TRISC2_bit;
//
void    init_sdc()
{
    //■■■■■■■■■■の初期化
    SPI1_Init_Advanced(_SPI_MASTER_OSC_DIV64,
_SPI_DATA_SAMPLE_MIDDLE, _SPI_CLK_IDLE_LOW, _SPI_LOW_2_HIGH);
    if (Mmc_Fat_Init()) {
        while (1) {
            LED = 1;
            Delay_ms(50);
            LED = 0;
            Delay_ms(50);
        }
    }
    SPI1_Init_Advanced(_SPI_MASTER_OSC_DIV16,
_SPI_DATA_SAMPLE_MIDDLE, _SPI_CLK_IDLE_LOW, _SPI_LOW_2_HIGH);
}
#endif
//*****
void    init_osc()
{
    OSCCON.IRCF2 = 1;
    OSCCON.IRCF1 = 1;
    OSCCON.IRCF0 = 1;
    OSCTUNE.PLEN = 1;
}
//*****
void    init_adc()
{
    ADCON1.PCFG3 = 0;
    ADCON1.PCFG2 = 1;
    ADCON1.PCFG1 = 0;
```

```
    ADCON1.PCFG0 = 0;
    ADCON1.VCFG1 = 0;
    ADCON1.VCFG0 = 0;
    //
    ADC_Init();
}
//*****
*****
void    init_port()
{
    TRISA = 0b11111111;
    TRISB = 0b11111110;
    TRISC = 0b11111111;
    //
    LED = 0;
}
//*****
*****
void    init_comparator()
{
    CMCON.CM2 = 1;
    CMCON.CM1 = 1;
    CMCON.CM0 = 1;
}
//*****
*****
```

FAT32ヘッダファイル

[_Lib_FAT32.h](#)

```
#ifdef __MIKROC_PRO_FOR_PIC32__
    #define __PIC32__
#endif

#ifdef __MIKROC_PRO_FOR_PIC__
    #define __PIC__
#endif

#ifdef __MIKROC_PRO_FOR_DSPIC__
    #define __dsPIC__
#endif

#ifdef __MIKROC_PRO_FOR_AVR__
    #define __AVR__
#endif

#ifdef __MIKROC_PRO_FOR_ARM__
    #define __ARM__
#endif
```

```
#define CR 0x0D // carriage return
#define LF 0x0A // line feed

////////////////////////////////////
////////
typedef unsigned short      uint8;
typedef   signed short      int8;
typedef unsigned int        uint16;
typedef   signed int        int16;
typedef unsigned long       uint32;
typedef   signed long       int32;
typedef unsigned long long  uint64;
typedef   signed long long  int64;

static const uint16 SECTOR_SIZE = 512;

////////////////////////////////////
////////
//
// modes of file operation:
//   - read  ( resets cursor to 0 )
//   - write ( resets cursor to 0 )
//   - append ( leaves cursor as is )
//
////////////////////////////////////
////////
static const uint8
    FILE_READ      = 0x01,
    FILE_WRITE     = 0x02,
    FILE_APPEND    = 0x04;

////////////////////////////////////
////////
//
// status and error codes returned by functions
//
////////////////////////////////////
////////
static const int8
    //////////////////////////////////
    // general status
    //////////////////////////////////
    OK              = 0,
    ERROR           = -1,
    FOUND           = 1,
    //////////////////////////////////
    // system errors
    //////////////////////////////////
    E_READ          = -1,
```

```

E_WRITE          = -2,
E_INIT_CARD     = -3,
E_BOOT_SIGN     = -4,
E_BOOT_REC      = -5,
E_FILE_SYS_INFO = -6,
E_DEVICE_SIZE   = -7,
//////////////////
// space related errors
//////////////////
E_LAST_ENTRY    = -10,
E_FREE_ENTRY    = -11,
E_CLUST_NUM     = -12,
E_NO_SWAP_SPACE = -13,
E_NO_SPACE      = -14,
//////////////////
// dir related errors
//////////////////
E_DIR_NAME      = -20,
E_ISNT_DIR     = -21,
E_DIR_EXISTS    = -22,
E_DIR_NOTFOUND = -23,
E_DIR_NOTEMPTY = -24,
//////////////////
// file related errors
//////////////////
E_FILE_NAME     = -30,
E_ISNT_FILE    = -31,
E_FILE_EXISTS   = -32,
E_FILE_NOTFOUND = -33,
E_FILE_NOTEMPTY = -34,
E_MAX_FILES     = -35,
E_FILE_NOTOPENED = -36,
E_FILE_EOF      = -37,
E_FILE_READ     = -38,
E_FILE_WRITE    = -39,
E_FILE_HANDLE   = -40,
//////////////////
// time related errors
//////////////////
E_TIME_YEAR     = -50,
E_TIME_MONTH    = -51,
E_TIME_DAY      = -52,
E_TIME_HOUR     = -53,
E_TIME_MINUTE   = -54,
E_TIME_SECOND   = -55;

//////////////////
//////////////////
// partition entry in MBR, 16B size
typedef struct
{

```

```
uint8      State[1];          // partition state. ACTIVE=0x80,
INACTIVE=0x00
uint8      __1[3];
uint8      Type[1];          // partition type. FAT16=0x06,
FAT32=0x0B
uint8      __2[3];
uint8      Boot[4];          // boot record sector number of
partition
uint8      Size[4];          // partition size in sectors
}
FAT32_PART;

////////////////////////////////////
////////////////////////////////////
// MBR, 512B size
typedef struct
{
    uint8      __1[446];
    FAT32_PART Part[4];
    uint8      BootSign[2];    // boot signature
}
FAT32_MBR;

////////////////////////////////////
////////////////////////////////////
// Boot Record, 512B size
typedef struct
{
    uint8      JmpCode[3];     // only way to say for certain if
it is boot sector
    uint8      __1[8];
    uint8      BytesPSect[2];  // # of bytes per sector
    uint8      SectsPCLust[1]; // # of sectors per cluster
    uint8      Reserved[2];    // # of reserved sectors
    uint8      FATCopies[1];   // # of FAT copies
    uint8      __2[4];
    uint8      MediaDesc[1];   // media descriptor
    uint8      __3[10];
    uint8      Sects[4];        // # of sectors in partition
    uint8      SectsPFAT[4];   // # of sectors per FAT table
    uint8      Flags[2];       // flags
    uint8      __4[2];
    uint8      RootClust[4];    // number of root dir cluster
    uint8      FSISect[2];     // FSI sector (offset from boot)
    uint8      BootBackup[2];  // sector number of boot sector
backup
    uint8      __5[14];
    uint8      ExtSign[1];     // extended signature - 0x29
    uint8      __6[4];
    uint8      VolName[11];    // volume name
```

```

    uint8    FATName[8];        // FAT name (FAT32)
    uint8    __7[420];
    uint8    BootSign[2];      // boot signature
}
FAT32_BR;

/////////////////////////////////////////////////////////////////
/////////////////////////////////////////////////////////////////
// File System Info, 512B size
typedef struct
{
    uint8    FirstSign[4];
    uint8    __1[480];
    uint8    FSISign[4];
    uint8    FreeSects[4];
    uint8    AllocClust[4];
    uint8    __2[14];
    uint8    BootSign[2];
}
FAT32_FSI;

/////////////////////////////////////////////////////////////////
/////////////////////////////////////////////////////////////////
typedef struct
{
    uint8    Entry[4];
}
FAT32_FATENT;

/////////////////////////////////////////////////////////////////
/////////////////////////////////////////////////////////////////
// directory entry, 32B size
typedef struct
{
    uint8    NameExt[11];      // file/directory name
    uint8    Attrib[1];        // file/directory attribute
    uint8    __1[2];
    uint8    CTime[2];         // create time
    uint8    CDate[2];         // create date
    uint8    ATime[2];
    uint8    HiClust[2];       // <-----|
    uint8    MTime[2];         // modification time |
    uint8    MDate[2];         // modification date |
    uint8    LoClust[2];       // <-----|----- 1st
cluster of file/folder
    uint8    Size[4];          // file size
}
FAT32_DIRENT;

/////////////////////////////////////////////////////////////////
/////////////////////////////////////////////////////////////////
/////////////////////////////////////////////////////////////////

```

```
//////////

typedef uint32  __CLUSTER;
typedef uint32  __SECTOR;
typedef uint32  __ENTRY;

typedef int8    __HANDLE;

//////////
//////////
// Time structure
typedef struct
{
    uint16      Year;
    uint8       Month;
    uint8       Day;
    uint8       Hour;
    uint8       Minute;
    uint8       Second;
}
__TIME;

//////////
//////////
// Partition info
typedef struct
{
    uint8       State; // partition status
    uint8       Type;  // partition type
    __SECTOR    Boot;  // partition start sector
    uint32      Size;  // partition size
}
__PART;

//////////
//////////
// FS info
typedef struct
{
    __PART      Part[1];
    uint16      BytesPSect; // bytes in sector
    uint8       SectsPCLust; // sectors in one cluster
    uint16      Reserved;
    uint8       FATCopies; // number of FAT table copies
    uint32      SectsPFAT; // number of sectors in one FAT table
    uint16      Flags;
    __SECTOR    FAT; // sector # of first FAT table
    __CLUSTER   Root; // cluster # of root directory
    __SECTOR    FSI; // sector # of FSI sector (relative to boot
sector)
```

```

    __SECTOR    Data;        // sector # of Data area
}
__INFO;

/////////////////////////////////////////////////////////////////
/////////////////////////////////////////////////////////////////
typedef struct
{
    char        NameExt[13]; // file/directory name
    uint8      _ATTRIB;     // file/directory attribute

    uint32      Size;       // file/directory size
    __CLUSTER   _1stClust;  // file/directory start cluster

    __CLUSTER   EntryClust; // file/directory entry cluster
    __ENTRY     Entry;      // file/directory entry index in entry
cluster
}
__DIR;

/////////////////////////////////////////////////////////////////
/////////////////////////////////////////////////////////////////
typedef struct
{
    __CLUSTER   _1stClust;  // file start cluster
    __CLUSTER   CurrClust;  // current file cluster

    __CLUSTER   EntryClust; // directory entry cluster
    __ENTRY     Entry;      // directory entry number in the entry
cluster

    uint32      Cursor;     // current file position (carret)
    uint32      Length;     // file size

    uint8       Mode;       // file open mode
}
__FILE;

/*
 * buffer for mmc/sd card sector r/w handling
 */
typedef struct
{
    __SECTOR     fSectNum;
    char         fSect[SECTOR_SIZE]; // sector buffer
}
__RAW_SECTOR;

/////////////////////////////////////////////////////////////////
/////////////////////////////////////////////////////////////////
extern const char  CRLF_F32[];

```

```
extern const uint8 FAT32_MAX_FILES;
extern const uint8 f32_fsi_template[SECTOR_SIZE];
extern const uint8 f32_br_template[SECTOR_SIZE];
extern      __FILE fat32_fdesc[];
extern      __RAW_SECTOR f32_sector;

////////////////////////////////////
////////////////////////////////////
extern  int8 FAT32_Dev_Init      (void);
extern  int8 FAT32_Dev_Read_Sector  (__SECTOR sc, char* buf);
extern  int8 FAT32_Dev_Write_Sector (__SECTOR sc, char* buf);
extern  int8 FAT32_Put_Char      (char ch);

////////////////////////////////////
////////////////////////////////////
int8    FAT32_Init      (void);
int8    FAT32_Format   (char *devLabel);

int8    FAT32_ReadDir  (__DIR *pDE);
int8    FAT32_ChangeDir (char *dname);
int8    FAT32_MakeDir  (char *dname);
int8    FAT32_Dir      (void);
int8    FAT32_Delete   (char *fn);
int8    FAT32_DeleteRec (char *fn);
int8    FAT32_Exists   (char *name);
int8    FAT32_Rename   (char *oldName, char *newName);
int8    FAT32_Open     (char *fn, uint8 mode);
int8    FAT32_Eof      (__HANDLE fHandle);
int8    FAT32_Read     (__HANDLE fHandle, char* rdBuf, uint16 len);
int8    FAT32_Write    (__HANDLE fHandle, char* wrBuf, uint16 len);
int8    FAT32_Seek     (__HANDLE fHandle, uint32 pos);
int8    FAT32_Tell     (__HANDLE fHandle, uint32 *pPos);
int8    FAT32_Close    (__HANDLE fHandle);
int8    FAT32_Size     (char *fname, uint32 *pSize);
int8    FAT32_MakeSwap (char *name, __SECTOR nSc, __CLUSTER *pCl);

int8    FAT32_SetTime  (__TIME *pTM);
int8    FAT32_IncTime  (uint32 Sec);

int8    FAT32_GetCTime (char *fname, __TIME *pTM);
int8    FAT32_GetMTime (char *fname, __TIME *pTM);

int8    FAT32_GetError (void);
////////////////////////////////////
////////////////////////////////////
```

動作確認

1. SDカード(FAT32)をカードスロットに挿入します。
2. 測定周期を設定します。
 - 100msec → SW_MODE_1=ON SW_MODE_0=ON
 - 1sec → SW_MODE_1=ON SW_MODE_0=OFF
 - 1min → SW_MODE_1=OFF SW_MODE_0=ON
 - 10min → SW_MODE_1=OFF SW_MODE_0=OFF
3. 平均測定回数を設定します。
 - 1回 → SW_MODE_3=ON SW_MODE_2=ON
 - 10回 → SW_MODE_3=ON SW_MODE_2=OFF
 - 100回 → SW_MODE_3=OFF SW_MODE_2=ON
 - 100回 → SW_MODE_3=OFF SW_MODE_2=OFF
4. 電源を入れます。
5. LEDが1秒周期で3回点滅するのを確認します。
6. スタートスイッチ(SW_START)を押下します。
7. LEDが点灯します。
8. ストップスイッチ(SW_STOP)を押下します。
9. 電源を切ります。
10. SDカードを抜いて、パソコンのカードスロットに挿入します。
11. エクスプローラで記録ファイルが存在することを確認します。

名前	更新日時	種類	サイズ
 LOG_0001	2012/12/27 0:00	テキスト ドキュメント	20 KB
 LOG_0002	2012/12/27 0:00	テキスト ドキュメント	1 KB
 LOG_0003	2012/12/27 0:00	テキスト ドキュメント	3 KB
 LOG_0004	2012/12/27 0:00	テキスト ドキュメント	3 KB
 LOG_0005	2012/12/27 0:00	テキスト ドキュメント	2 KB

12. ファイルの内容を確認します。

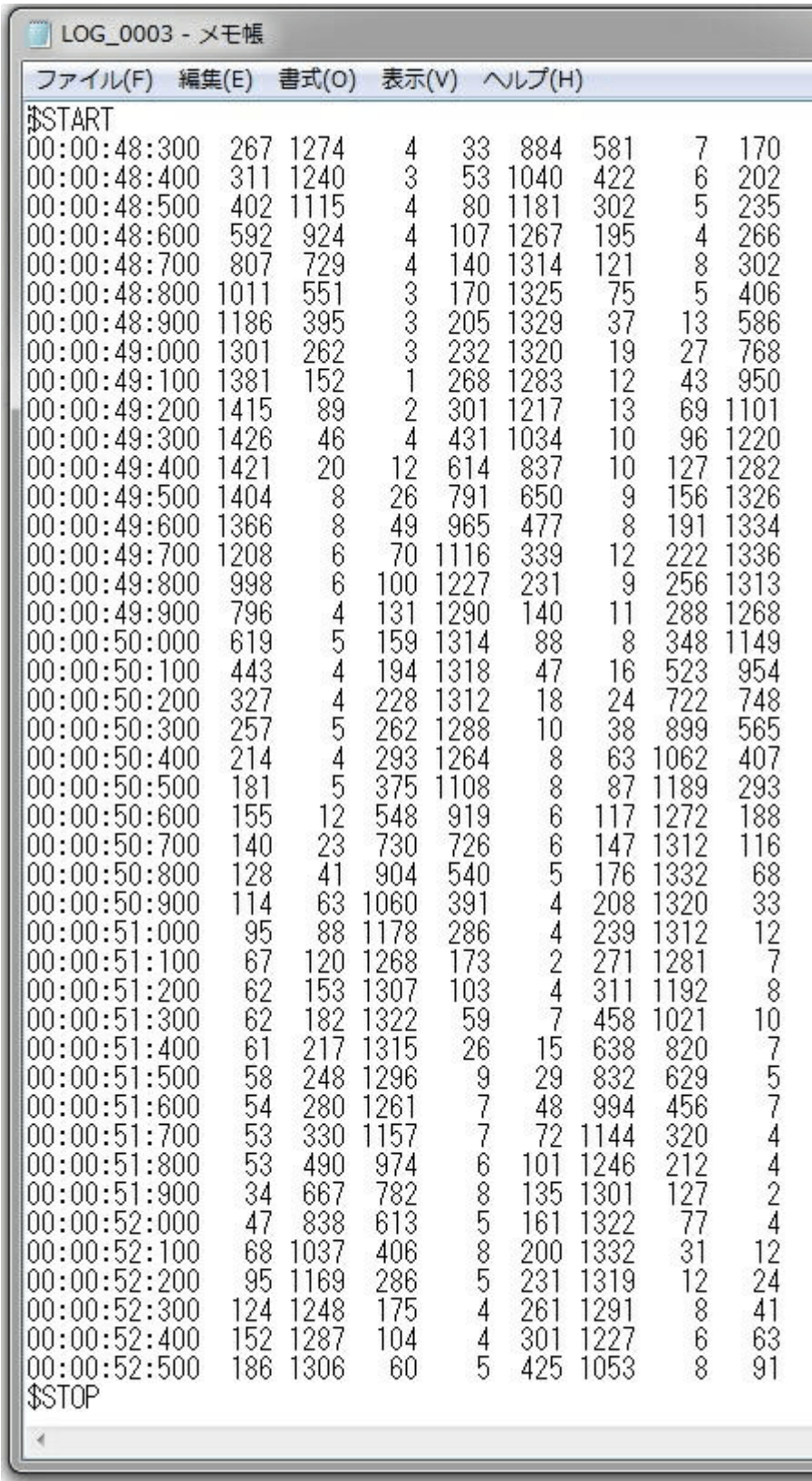

```
LOG_0003 - メモ帳
ファイル(F) 編集(E) 書式(O) 表示(V) ヘルプ(H)
$START
00:00:48:300 267 1274 4 33 884 581 7 170
00:00:48:400 311 1240 3 53 1040 422 6 202
00:00:48:500 402 1115 4 80 1181 302 5 235
00:00:48:600 592 924 4 107 1267 195 4 266
00:00:48:700 807 729 4 140 1314 121 8 302
00:00:48:800 1011 551 3 170 1325 75 5 406
00:00:48:900 1186 395 3 205 1329 37 13 586
00:00:49:000 1301 262 3 232 1320 19 27 768
00:00:49:100 1381 152 1 268 1283 12 43 950
00:00:49:200 1415 89 2 301 1217 13 69 1101
00:00:49:300 1426 46 4 431 1034 10 96 1220
00:00:49:400 1421 20 12 614 837 10 127 1282
00:00:49:500 1404 8 26 791 650 9 156 1326
00:00:49:600 1366 8 49 965 477 8 191 1334
00:00:49:700 1208 6 70 1116 339 12 222 1336
00:00:49:800 998 6 100 1227 231 9 256 1313
00:00:49:900 796 4 131 1290 140 11 288 1268
00:00:50:000 619 5 159 1314 88 8 348 1149
00:00:50:100 443 4 194 1318 47 16 523 954
00:00:50:200 327 4 228 1312 18 24 722 748
00:00:50:300 257 5 262 1288 10 38 899 565
00:00:50:400 214 4 293 1264 8 63 1062 407
00:00:50:500 181 5 375 1108 8 87 1189 293
00:00:50:600 155 12 548 919 6 117 1272 188
00:00:50:700 140 23 730 726 6 147 1312 116
00:00:50:800 128 41 904 540 5 176 1332 68
00:00:50:900 114 63 1060 391 4 208 1320 33
00:00:51:000 95 88 1178 286 4 239 1312 12
00:00:51:100 67 120 1268 173 2 271 1281 7
00:00:51:200 62 153 1307 103 4 311 1192 8
00:00:51:300 62 182 1322 59 7 458 1021 10
00:00:51:400 61 217 1315 26 15 638 820 7
00:00:51:500 58 248 1296 9 29 832 629 5
00:00:51:600 54 280 1261 7 48 994 456 7
00:00:51:700 53 330 1157 7 72 1144 320 4
00:00:51:800 53 490 974 6 101 1246 212 4
00:00:51:900 34 667 782 8 135 1301 127 2
00:00:52:000 47 838 613 5 161 1322 77 4
00:00:52:100 68 1037 406 8 200 1332 31 12
00:00:52:200 95 1169 286 5 231 1319 12 24
00:00:52:300 124 1248 175 4 261 1291 8 41
00:00:52:400 152 1287 104 4 301 1227 6 63
00:00:52:500 186 1306 60 5 425 1053 8 91
$STOP
```

13. ファイルの内容を、Excelにコピー&ペーストします。

Microsoft Excel - 簡易ADロガー-(FAT32)

ファイル(E) 編集(E) 表示(V) 挿入(I) 書式(O) ツール(I) データ(D)

100% MS Pゴシック

E38

	A	B	C	D	E	F	G	H	I
1	TIME	CH1	CH2	CH3	CH4	CH5	CH6	CH7	CH8
2	00:00:06.000	962	7	54	756	259	8	169	899
3	00:00:07.000	113	53	754	269	9	169	907	19
4	00:00:08.000	71	754	273	9	165	909	17	20
5	00:00:09.000	832	283	2	160	919	30	18	485
6	00:00:10.000	351	5	154	924	35	19	437	609
7	00:00:11.000	67	145	929	38	12	375	671	8
8	00:00:12.000	155	927	34	8	347	717	8	95
9	00:00:13.000	1019	38	4	296	767	11	89	906
10	00:00:14.000	168	4	269	808	12	82	894	152
11	00:00:15.000	62	246	840	9	74	865	174	5
12	00:00:16.000	273	862	3	64	849	213	8	191
13	00:00:17.000	960	7	56	810	252	11	180	936
14	00:00:18.000	115	52	772	286	7	170	938	20
15	00:00:19.000	63	716	337	9	160	941	26	16
16	00:00:20.000	740	400	4	145	949	43	11	403
17	00:00:21.000	495	5	130	945	59	10	314	775
18	00:00:22.000	70	111	940	82	8	236	874	8
19	00:00:23.000	110	912	112	7	221	898	10	53
20	00:00:24.000	973	147	3	198	920	12	40	710
21	00:00:25.000	269	5	181	936	16	27	612	457
22	00:00:26.000	65	163	940	26	18	497	558	6
23	00:00:27.000	165	936	33	12	398	674	9	103
24	00:00:28.000	1028	43	4	288	786	12	85	913
25	00:00:29.000	184	6	229	888	13	67	854	211

14. 内容をグラフ表示させます。

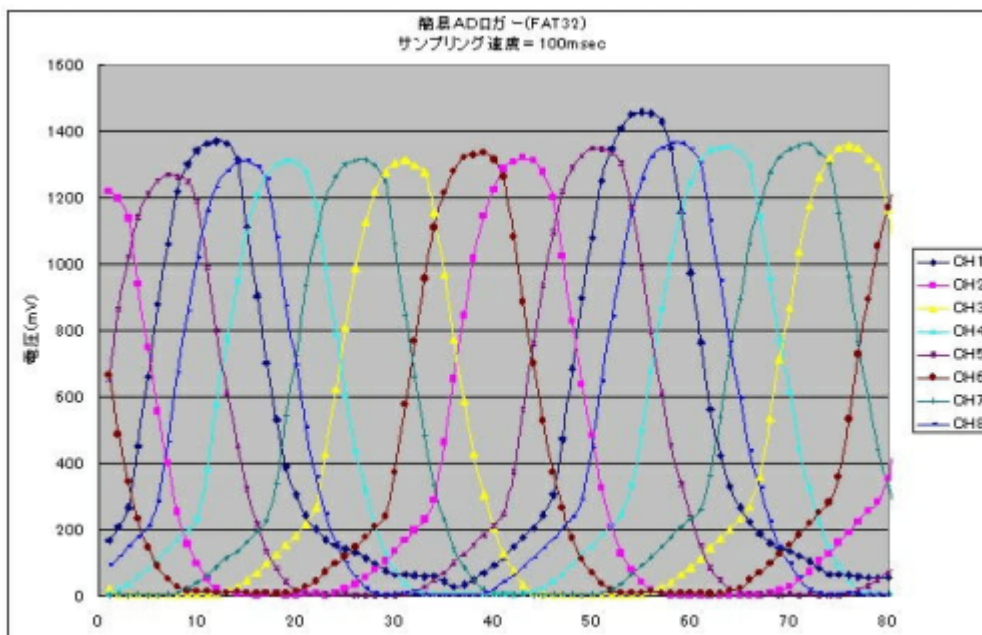

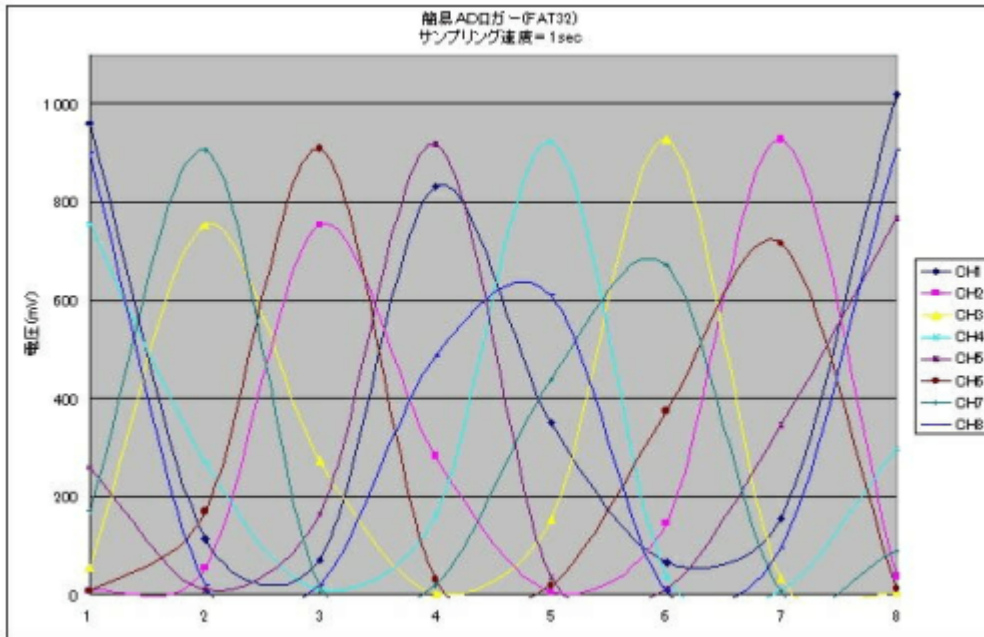

著作権表示 copyright notice

このページは稲崎様の閉鎖したHPのコピーで、著作権は稲崎様にあります。詳細 This page is a copy of Mr. Inasaki's closed website, and the copyright is held by him. [Details](#)

From: <http://www.deepsky.jp/wiki/> - うごくといいな

Permanent link: <http://www.deepsky.jp/wiki/doku.php?id=elechobby:picdic:otherpic:194&rev=1588330669>

Last update: 2025/10/17 14:27

